

GENUINE FOODS AND EQUIPMENTS

(ISO 9001: 2015 CERTIFIED COMPANY)



REGD-OFFICE:

Senthil Nagar, Varadharajapuram, Chennai - 600 048.

WORKS:

No – 5/18 A, Kallangadu, Kadampadi, Sulur, Coimbatore - 641 401.

Mail- sales@genuineequipments.com.

Web www.Genuineequipments.com

Mob – 98400 73979, 78459 72789, 97894 07896

SEPARATION EQUIPMENTS

- **PLATE MAGNET**
- **TUBE MAGNET**
- **HUMP MAGNET**
- **DEEP REACH MAGNET**
- **GRILL MAGNET**
- **GRATES-IN-HOUSING**
- **SB FERROUS TRAP (LIQUID LINE)**
- **ROTA GRATE MAGNET**
- **SUSPENDED PERMANENT
MAGNET**
- **ROLL MAGNET**
- **DRUM MAGNET**
- **METAL DETECTOR**
- **METAL SEPARATOR**



MAGNET SELECTION METHODS

Ferrite Magnet

1,000 to 3,500

Gauss power

Basic protection from tramp metals damaging downstream equipment. Ceramic magnets and quality construction at rock-bottom prices.

Designed To Remove



Medium to Large Tramp Metal

Rare Earth Magnet

4,000 to 8,000

Gauss power

Prevents product contamination and tramp metal damage. Assemblies feature stainless steel construction, high-power rare earth magnets with demanding attention to welds and finish.



Small Ferrous Contamination

Strong Rare Earth

10,000 to 14,000

Gauss power

The ultimate in process purity combines the finest materials and construction techniques with the industry's most powerful RE7 Xtreme Rare Earth magnetic circuits. When you can accept nothing less than the absolute best.

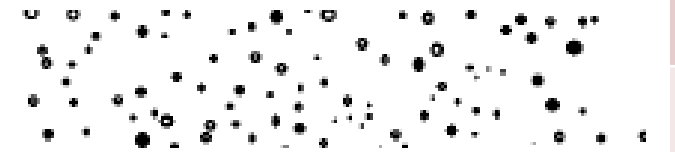

Weakly Magnetic
Fine Ferrous Contamination

PLATE MAGNET

- **PROTECTS AGAINST MEDIUM AND SMALL SIZE CONTAMINANTS**
- **INSTALLED IN CHUTES, SPOUTS, DUCTS AND SUSPENDED OVER CONVEYORS AND SCREENS**
- **AVAILABLE IN MULTIPLE DESIGNS; CERAMIC, RARE EARTH AND XTREME RARE EARTH**



TUBE MAGNET

- INCH DIAMETER TUBES, CERAMIC AND RARE EARTH OPTIONS
- SS 316L CONSTRUCTION, CUSTOMIZED TO ANY LENGTH
- CAPABLE TO HANDLING TEMPERATURE UP TO 200°C



HUMP MAGNET

- **INCORPORATES TWO PLATE MAGNETS FOR IMPROVED SEPARATION**
- **MATERIAL FALLS ON FIRST PLATE MAGNET, THEN REDIRECTS TO SECOND MAGNET**
- **VARIOUS STRENGTHS AVAILABLE, FITS FEED PIPES UP TO 18"**
- **AUTOMATIC CLEANING OPTION AVAILABLE, INSTALLED IN CHUTES AND SPOUTS**

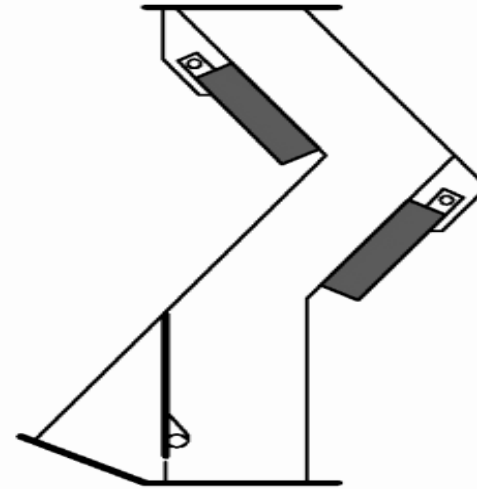

DEEP REACH MAGNET

- **LOW PROFILE IDEAL FOR TIGHT SPACES**
- **XTREME RARE EARTH MAGNET CIRCUITS AVAILABLE TO REMOVE FINE OR WEAKLY MAGNETIC CONTAMINANTS**
- **EASY TO CLEAN OPTION AVAILABLE**



GRILL MAGNET

- REMOVES FINE IRON FROM DRY, FREE FLOWING PRODUCTS
- FITS SQUARE, ROUND, OVAL AND ODD SHAPED HOPPERS / CHUTES
- AVAILABLE IN CERAMIC AND RARE EARTH MAGNET
- VARIOUS SIZES AVAILABLE

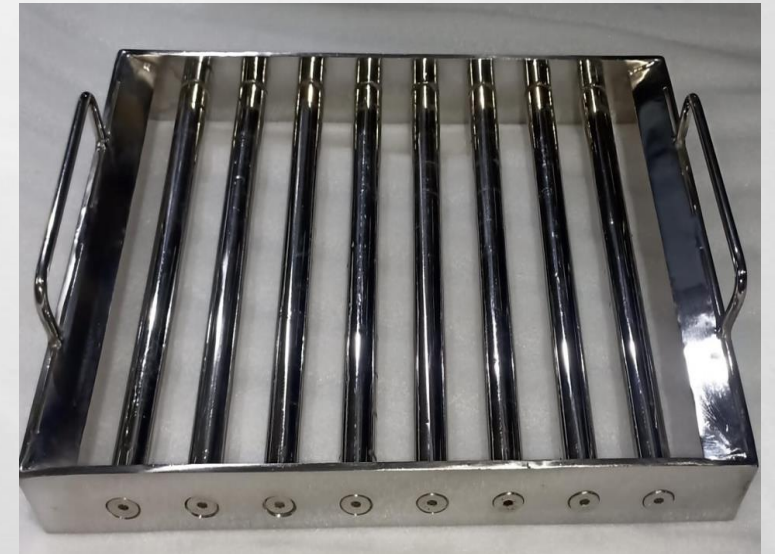

GRATES-IN-HOUSING

- **STAGGERED ROWS OF GRATES IN A CUSTOM HOUSING**
- **GREATER OPPORTUNITY TO REMOVE FINE IRON DUST FROM FREE-FLOWING PRODUCTS**
- **AVAILABLE IN CERAMIC AND RARE EARTH MAGNET**
- **SINGLE OR MULTIPLE BANK DESIGN AVAILABLE**



SB FERROUS TRAP (LIQUID LINE)

- REMOVES SCALE, OXIDES AND IRON CONTAMINANTS IN LIQUID AND SLURRY LINE
- FOR USE IN 2 TO 4" PIPE LINE, WITH STAND PRESSURE UP TO 10 BAR (150 PSI), AVAILABLE IN CERAMIC AND RARE EARTH MAGNET
- EASY TO CLEAN OPTION AVAILABLE



ROTA GRATE MAGNET

- **SLOWLY ROTATING TUBE CIRCUIT, DESIGNED FOR NON-FREE FLOWING MATERIALS**
- **GREATER OPPORTUNITY TO REMOVE SMALL IRON PARTICULATES**
- **AVAILABLE IN CERAMIC AND RARE EARTH MAGNET**
- **AUTOMATIC CLEANING OPTION AVAILABLE**



SUSPENDED PERMANENT MAGNET

- AUTOMATICALLY REMOVE LARGE AMOUNTS OF FERROUS FROM NON-FERROUS MATERIALS CONVEYED IN HEAVY BURDEN DEPTHS ON ALMOST ANY TYPE OF CONVEYOR OR CHUTE. IDEAL FOR SEPARATION APPLICATIONS ON WET OR DRY, FINE OR COARSE MATERIALS, LARGE OR SMALL TONNAGES. MANUAL CLEANING MODELS ARE AVAILABLE WITH MECHANICAL DRAWER TYPE STRIPPERS. SELF-CLEANING MODELS ALSO AVAILABLE.



ROLL MAGNET WORKING PRINCIPLE

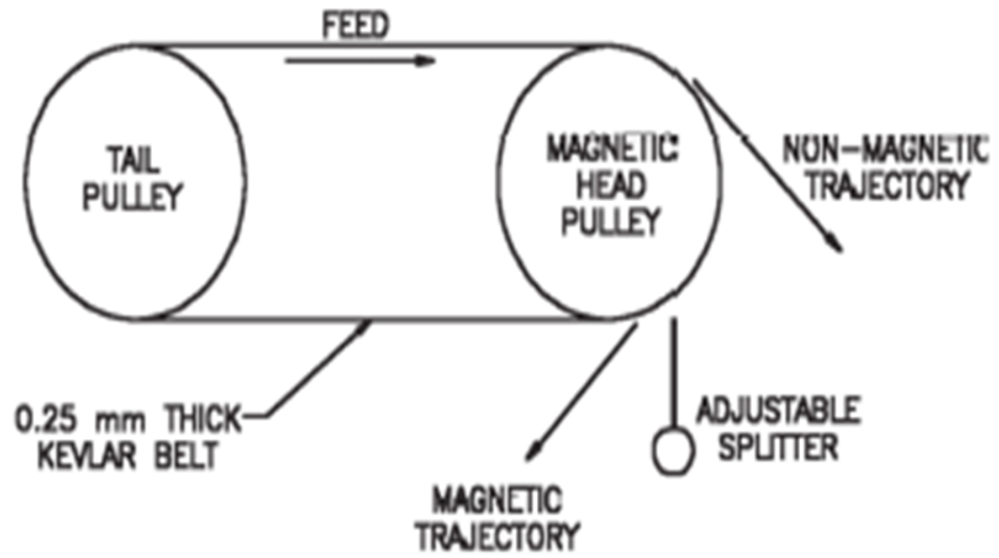
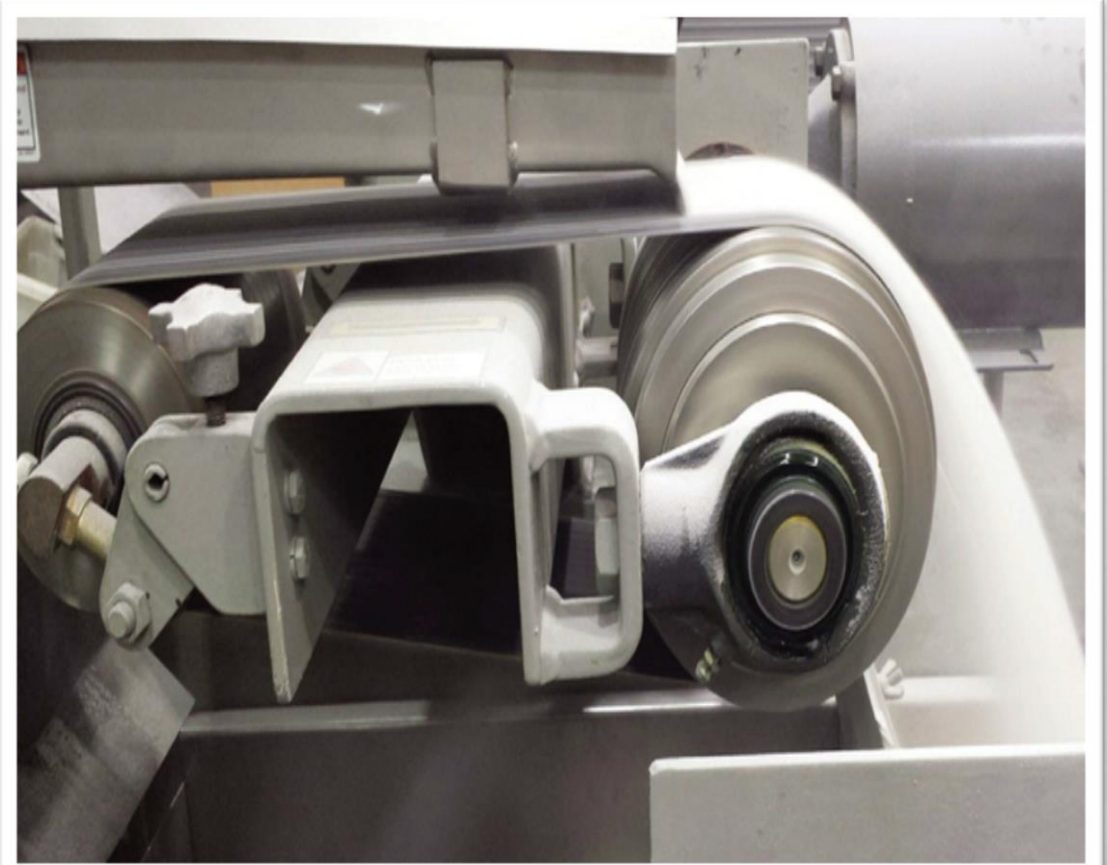
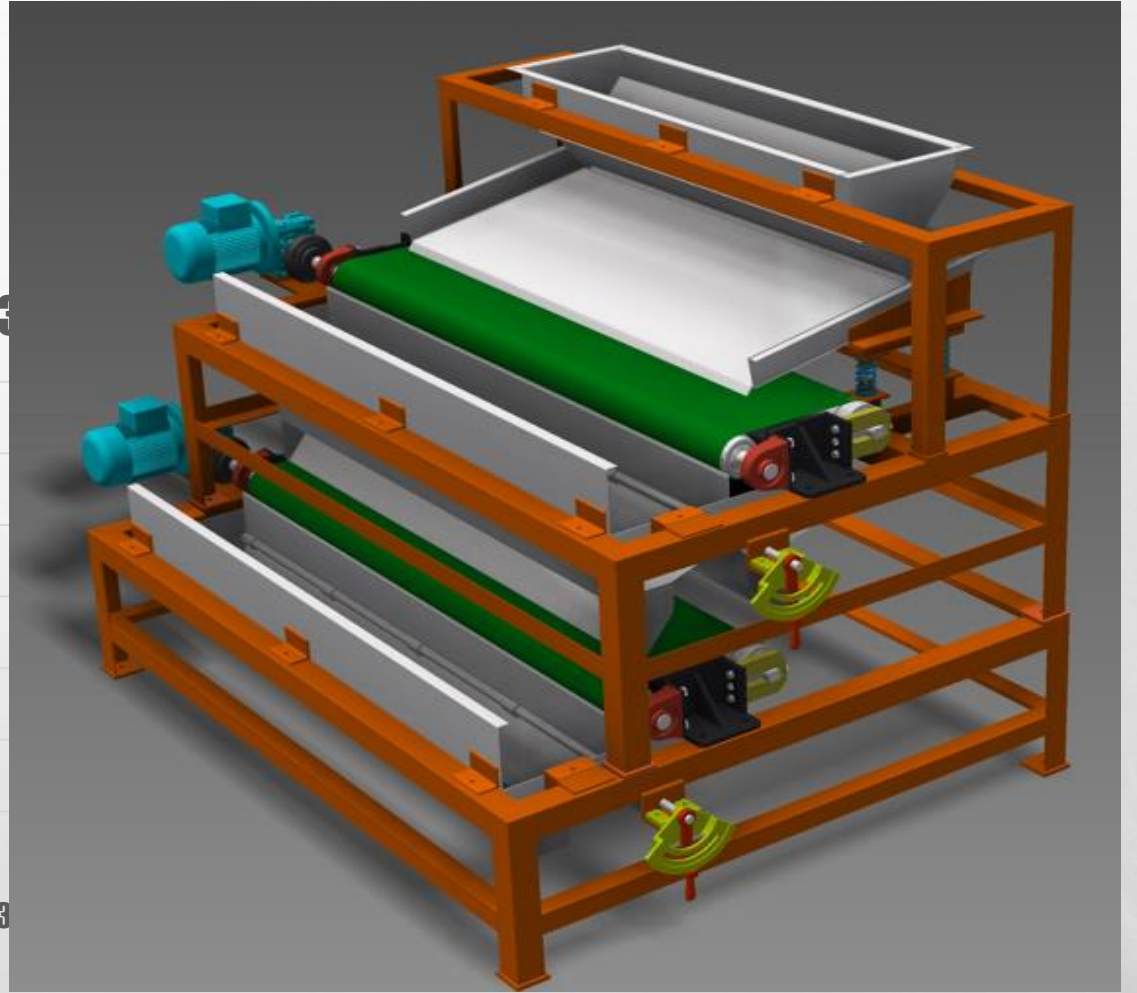

Fig 1: Schematic of the Rare Earth Roll Magnetic Separator



RARE EARTH ROLL MAGNET



RARE EARTH ROLL MAGNET

- RARE EARTH ROLL SEPARATORS ARE EFFECTIVE AT CONCENTRATING OR REMOVING WEAKLY MAGNETIC PARTICLES FROM A DRY PROCESS STREAM. THE RE ROLL OPERATES AS A PULLEY IN A SELF-CONTAINED HOUSING. A HOPPER AND VIBRATORY FEEDER SPREAD THE MATERIAL ONTO A THIN BELT, WHICH IS THEN CONVEYED OVER THE MAGNETIC ROLL FOR SEPARATION. THESE SEPARATORS OFTEN CONTAIN MULTIPLE ROLLS USED IN A SERIES TO ENHANCE THE SEPARATION OR PURITY OF THE PRODUCT.

VFD CONTROLLER

- A VARIABLE-FREQUENCY DRIVE (VFD, OR ADJUSTABLE-FREQUENCY DRIVE, ADJUSTABLE-SPEED DRIVE, VARIABLE-SPEED DRIVE, AC DRIVE, MICRO DRIVE, INVERTER DRIVE, OR DRIVE) IS A TYPE OF AC MOTOR DRIVE (SYSTEM INCORPORATING A MOTOR) THAT **CONTROLS SPEED AND TORQUE BY VARYING THE FREQUENCY OF THE INPUT ELECTRICITY.**
- **CONTROL PANEL:** CONTAINS ON/OFF, EMERGENCY BUSH BUTTON, TO CONTROL VFT TO ROLL MAGNET WITH IP 66 MODEL.

Model	Roll Diameter (mm)	Roll width (mm)	Light materials (kgs/Hr)	Heavy material (kgs/Hr)
GR 100/300	100	300	250-600	800-1500
GR 100/500	100	500	600-1000	1500-2500
GR 100/750	100	750	1000-1500	2500-4000
GR 100/1000	100	1000	1500-2000	4000-5000
GR 100/1250	100	1250	2000-3000	5000-6000
GR 100/1500	100	1500	3000-5000	6000-7000
GR 150/1000	150	1000	3000-5000	7000-8000
GR 150/1250	150	1250	5000-8000	9000-12000
GR 150/1500	150	1500	8000-12000	12000-15000

DRUM MAGNETS

- DRUM MAGNETS ARE SELF-CLEANING MAGNET ASSEMBLIES THAT CONTINUOUSLY REMOVE TRAMP METAL FROM A PRODUCT FLOW. THE MAGNET ASSEMBLY IS ENCLOSED WITHIN A STAINLESS STEEL DRUM AND FIXED IN POSITION. THE DRUM ROTATES AROUND THE MAGNET CONVEYING MATERIAL THROUGH THE MAGNETIC FIELD. CLEAN OR NONFERROUS MATERIAL CASCADES OFF THE DRUM FACE WHILE THE MAGNETIC MATERIAL IS DRAWN AROUND THE DRUM AND DISCHARGED AT THE BOTTOM. DRUM SEPARATORS USE CERAMIC MAGNET CIRCUITS TO REMOVE RELATIVELY LARGE FERROUS MATERIAL SUCH AS NUTS, BOLTS, STAPLES, AND WELDING ROD FROM A DRY PRODUCT FLOWS.

DRUM MAGNET INSIDE VIEW



DRUM MAGNET WORKING PRINCIPLE

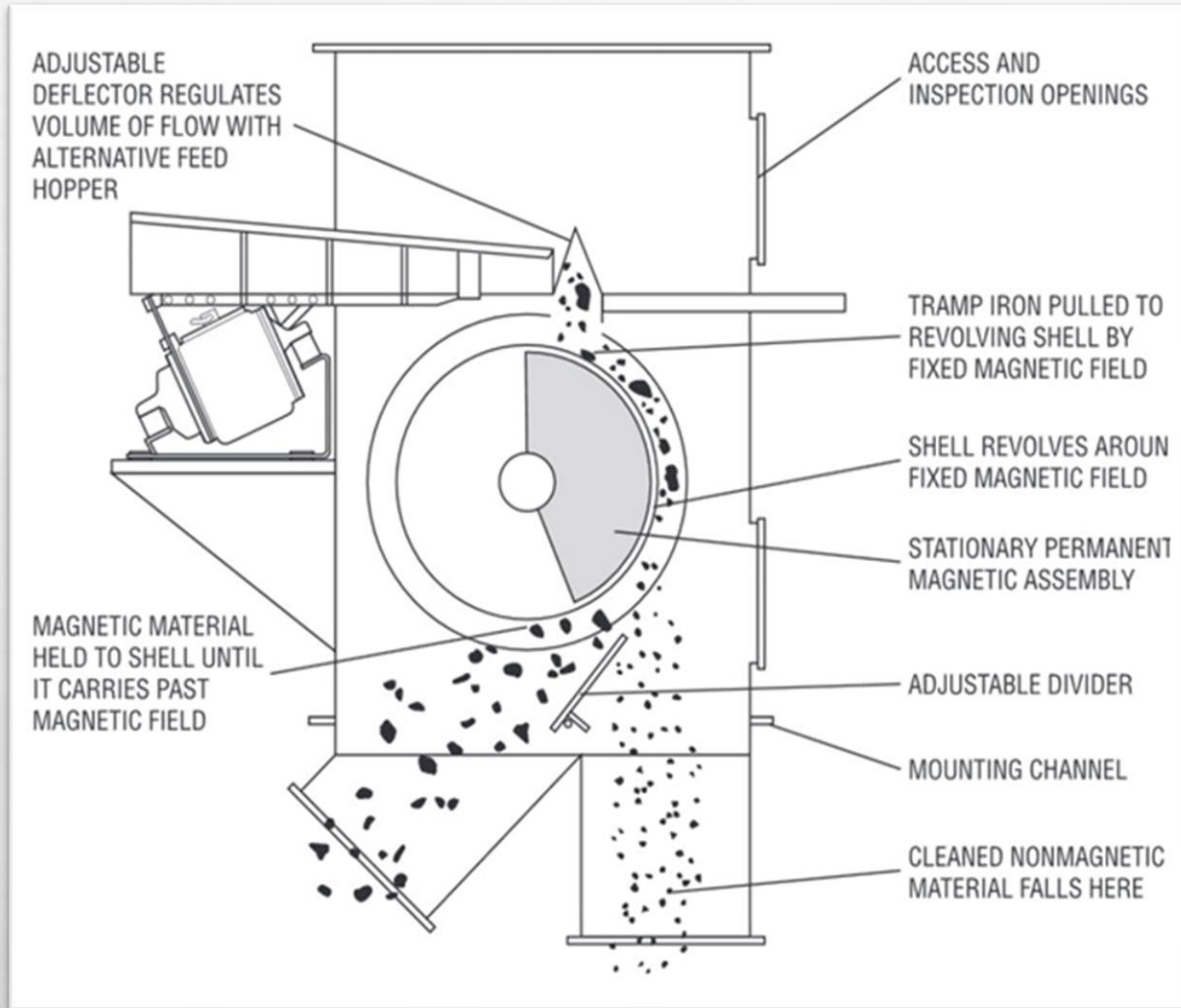

METAL DETECTOR

THE COMPACT METAL DETECTION SYSTEM OFFERS SAFE PERFORMANCE WITH ITS ROBUST STAINLESS STEEL CONVEYOR BELT AND HIGH DETECTION SENSITIVITY, WITH ITS ROBUST STAINLESS STEEL CONVEYOR BELT CAN DETECT PIECE GOODS OF FROM 50 GRAM TO 50 KG PACKED PRODUCTS.



METAL SEPARATOR

- METAL SEPARATORS SENSE AND REMOVE THE PRESENCE OF FERROUS, NONFERROUS AND STAINLESS METALS IN A PROCESS AS A PACKAGED ITEM.
- ALL FOOD-GRADE (OR HIGHER) COME STANDARD WITH METAL-DETECTABLE GASKETS & GROMMETS.



WORKING PRINCIPLE

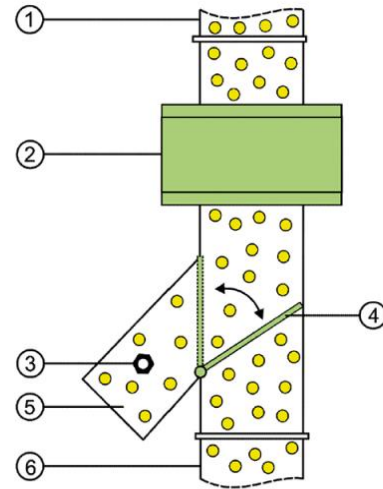

- | | |
|------------------------|--------------------|
| 1. Inlet | 4. Reject Flap |
| 2. Detection Coil | 5. Reject Outlet |
| 3. Metal Contamination | 6. Material Outlet |



3. Metal Contamination
2. Detection Coil
1. Inlet

6. Material Outlet
5. Reject Outlet
4. Reject Flap

OUR TRIAL AND TESTING CENTER

